

REVISIONS			
REV	DESCRIPTION	DATE	APPROVED

NOTES:

1. THE PRODUCT SHOWN HEREIN IS DESIGNED AND MANUFACTURED TO COMPLY WITH REQUIREMENTS OF THE FLORIDA BUILDING CODE.
2. WOOD FRAMING AND MASONRY OPENING TO BE DESIGNED AND ANCHORED TO PROPERLY TRANSFER ALL LOADS TO STRUCTURE. FRAMING AND MASONRY OPENING IS THE RESPONSIBILITY OF THE ARCHITECT OR ENGINEER OF RECORD.
3. 1X BUCK OVER MASONRY/CONCRETE IS OPTIONAL.
4. WHERE SHIM OR BUCK THICKNESS IS LESS THAN 1-1/2" UNITS MUST BE ANCHORED THROUGH THE FRAME IN ACCORDANCE WITH MANUFACTURER'S PUBLISHED INSTALLATION INSTRUCTIONS. ANCHORS SHALL BE SECURELY FASTENED DIRECTLY INTO MASONRY, CONCRETE OR OTHER STRUCTURAL SUBSTRATE MATERIAL.
5. WHERE WOOD BUCK THICKNESS IS 1-1/2" OR GREATER, BUCK SHALL BE SECURELY FASTENED TO MASONRY, CONCRETE OR OTHER STRUCTURAL SUBSTRATE. UNITS MAY BE ANCHORED THROUGH FRAME TO SECURED WOOD BUCK IN ACCORDANCE WITH MANUFACTURER'S PUBLISHED INSTALLATION INSTRUCTIONS.
6. WHERE 1X BUCK IS NOT USED DISSIMILAR MATERIALS MUST BE SEPARATED WITH APPROVED COATING OR MEMBRANE. SELECTION OF COATING OR MEMBRANE IS THE RESPONSIBILITY OF THE ARCHITECT OR ENGINEER OF RECORD.
7. BUCKS SHALL EXTEND BEYOND UNIT FRAME INTERIOR FACE SO THAT FULL FRAME SUPPORT IS PROVIDED.
8. FOR FIN INSTALLATION SHIM AS NEEDED. FOR FRAME INSTALLATION SHIM AS REQUIRED AT EACH ANCHOR LOCATION WITH LOAD BEARING SHIM. SHIM WHERE SPACE OF 1/16" OR GREATER OCCURS. MAXIMUM ALLOWABLE SHIM STACK TO BE 1/4".
9. SHIMS SHALL BE LOCATED, APPLIED AND MADE FROM MATERIALS AND THICKNESS CAPABLE OF SUSTAINING APPLICABLE LOADS.
10. WIND LOAD DURATION FACTOR Cd=1.6 WAS USED FOR WOOD ANCHOR CALCULATIONS.
11. FRAME MATERIAL: EXTRUDED RIGID PVC.
12. UNITS MUST BE GLAZED PER ASTM E1300-04/09, WITH SAFETY GLAZING.
13. APPROVED IMPACT PROTECTIVE SYSTEM IS REQUIRED FOR THIS PRODUCT IN WIND BORNE DEBRIS REGIONS.
14. FOR ANCHORING THROUGH FIN INTO WOOD FRAMING OR 2X BUCK USE #8 WOOD SCREWS WITH SUFFICIENT LENGTH TO ACHIEVE A 1 1/4" MINIMUM EMBEDMENT INTO SUBSTRATE. LOCATE ANCHORS AS SHOWN IN ELEVATIONS AND INSTALLATION DETAILS.

15. FOR ANCHORING THROUGH FRAME INTO WOOD FRAMING OR 2X BUCK USE #12 WOOD SCREWS WITH SUFFICIENT LENGTH TO ACHIEVE A 1 3/8" MINIMUM EMBEDMENT INTO SUBSTRATE. LOCATE ANCHORS AS SHOWN IN ELEVATIONS AND INSTALLATION DETAILS.
16. FOR ANCHORING THROUGH FRAME INTO MASONRY/CONCRETE USE 1/4" TAPCONS WITH SUFFICIENT LENGTH TO ACHIEVE A 1 1/4" MINIMUM EMBEDMENT INTO SUBSTRATE WITH 2" MINIMUM EDGE DISTANCE. LOCATE ANCHORS AS SHOWN IN ELEVATIONS AND INSTALLATION DETAILS.
17. FOR ANCHORING THROUGH FRAME INTO METAL STRUCTURE USE #12 SMS OR SELF DRILLING SCREWS WITH SUFFICIENT LENGTH TO ACHIEVE 3 THREADS MINIMUM BEYOND STRUCTURE INTERIOR WALL. LOCATE ANCHORS AS SHOWN IN ELEVATIONS AND INSTALLATION DETAILS.
18. ALL FASTENERS TO BE CORROSION RESISTANT.
19. INSTALLATION ANCHORS SHALL BE INSTALLED IN ACCORDANCE WITH ANCHOR MANUFACTURER'S INSTALLATION INSTRUCTIONS AND ANCHORS SHALL NOT BE USED IN SUBSTRATES WITH STRENGTHS LESS THAN THE MINIMUM STRENGTH SPECIFIED BELOW:
 - A. WOOD: MINIMUM SPECIFIC GRAVITY OF G=0.42
 - B. CONCRETE: MINIMUM COMPRESSIVE STRENGTH OF 2,000 PSI.
 - C. MASONRY: HOLLOW/FILLED BLOCK PER ASTM C90 WITH Fm=2,000PSI MINIMUM.
 - D. METAL STRUCTURE: STEEL 18GA (.048") FY=33KSI/FU=52KSI OR ALUMINUM 6063-T5 FU=30KSI .048" THICK MINIMUM

SIGNED: 02/06/2019

TABLE OF CONTENTS	
SHEET NO.	DESCRIPTION
1	NOTES
2 - 3	ELEVATIONS
4 - 6	INSTALLATION DETAILS
7	COMPONENTS

STERGIS WINDOWS & DOORS 79 WALTON STREET ATTLEBORO, MA 02703		
SERIES 623.620 VINYL SGD NON-IMPACT NOTES		
DRAWN: A.R.	DWG NO. 08-03378	REV -
SCALE NTS	DATE 02/06/19	SHEET 1 OF 7
L. ROBERTO LOMAS P.E. 1432 WOODFORD RD LEWISVILLE, NC 27023 434-688-0609 rllomas@rlomaspe.com		



Luis R. Lomas P.E.
FL No.: 62514

REVISIONS			
REV	DESCRIPTION	DATE	APPROVED

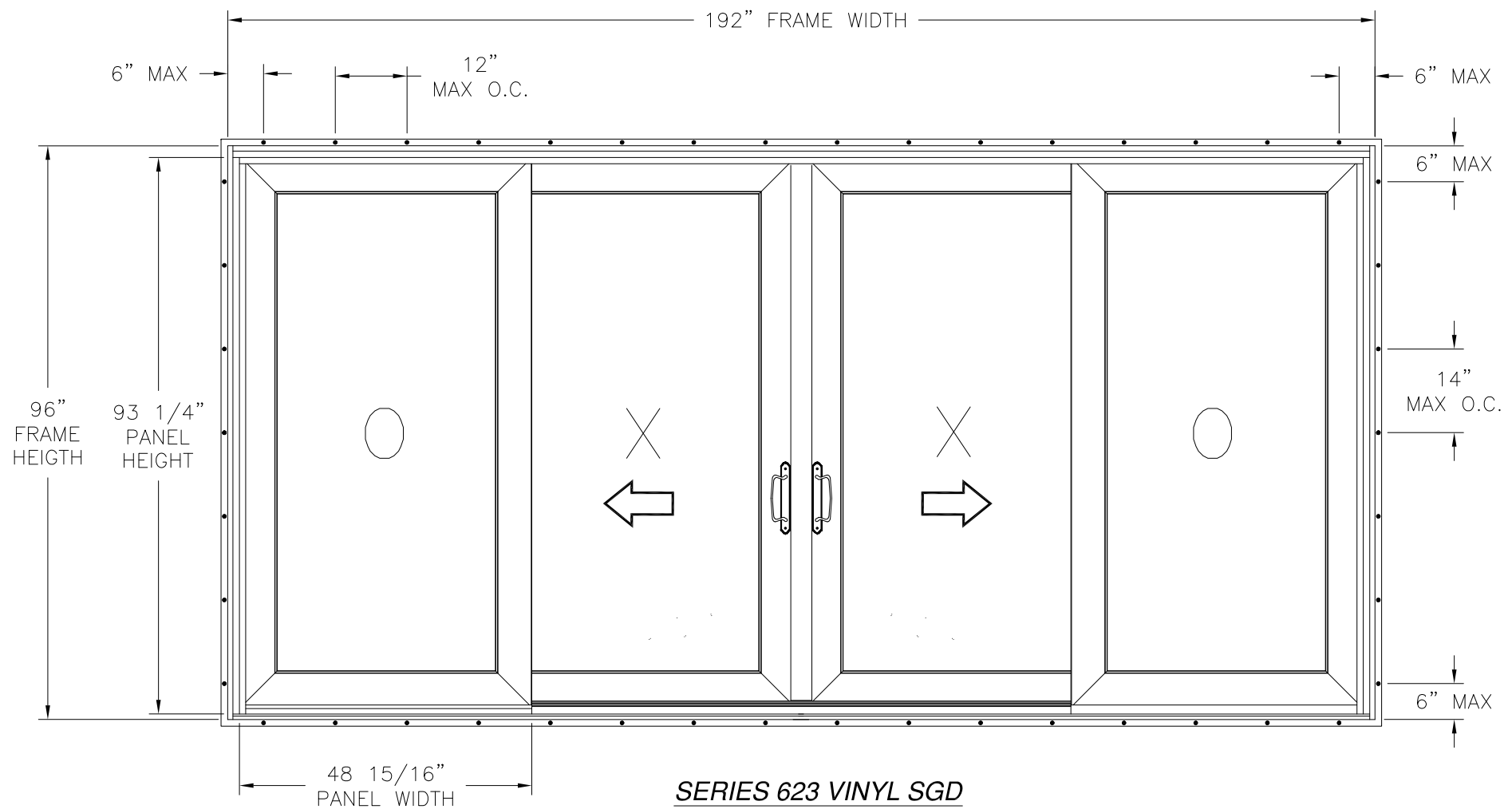
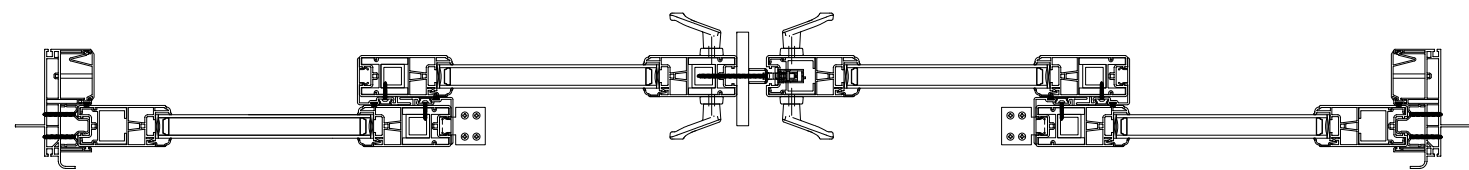

SERIES 623 VINYL SGD
EXTERIOR VIEW FIN INSTALLATION

DESIGN PRESSURE RATING	IMPACT RATING
±50.0PSF	NONE

4 PANELS SHOWN, UNLIMITED CONFIGURATIONS UP TO 4 PANELS IS APPLICABLE
AS LONG AS INDIVIDUAL PANEL AREA DOES NOT EXCEED 31.69 FT²

- NOTES:
- PANEL SIZE: 48 15/16" X 93 1/4"
 - D.L.O.: 40 3/4" X 85"

SIGNED: 02/06/2019

STERGIS WINDOWS & DOORS
79 WALTON STREET
ATTLEBORO, MA 02703

SERIES 623.620 VINYL SGD
NON-IMPACT
ELEVATION

DRAWN: A.R.	DWG NO. 08-03378	REV -
SCALE NTS	DATE 02/06/19	SHEET 2 OF 7

L. ROBERTO LOMAS P.E.
1432 WOODFORD RD LEWISVILLE, NC 27023
434-688-0609 rllomas@lrlomaspe.com



Luis R. Lomas P.E.
FL No.: 62514

HARDWARE SCHEDULE

A.	(4) STEEL ADJUSTABLE TANDEM ROLLER AT EACH OPERABLE PANEL BOTTOM RAIL CORNER
B.	(2) INSIDE/OUTSIDE PULL HANDLE AT LOCK STILE OF OPERABLE PANEL
C.	(1) AMESBURY 2 POINT LOCK AT STILE OF OPERABLE PANEL, 38 1/4" FROM BOTTOM OF PANEL
D.	(1) STEEL KEEPER AT LATCH STILE OF OPERABLE PANEL, 38 1/4" FROM BOTTOM OF PANEL
E.	(1) H SHAPED ALUMINUM REINFORCEMENT AT EACH FIXED PANEL ASTRAGAL AND INTERLOCK STILES AND OPERABLE PANEL INTERLOCK STILE

REVISIONS			
REV	DESCRIPTION	DATE	APPROVED

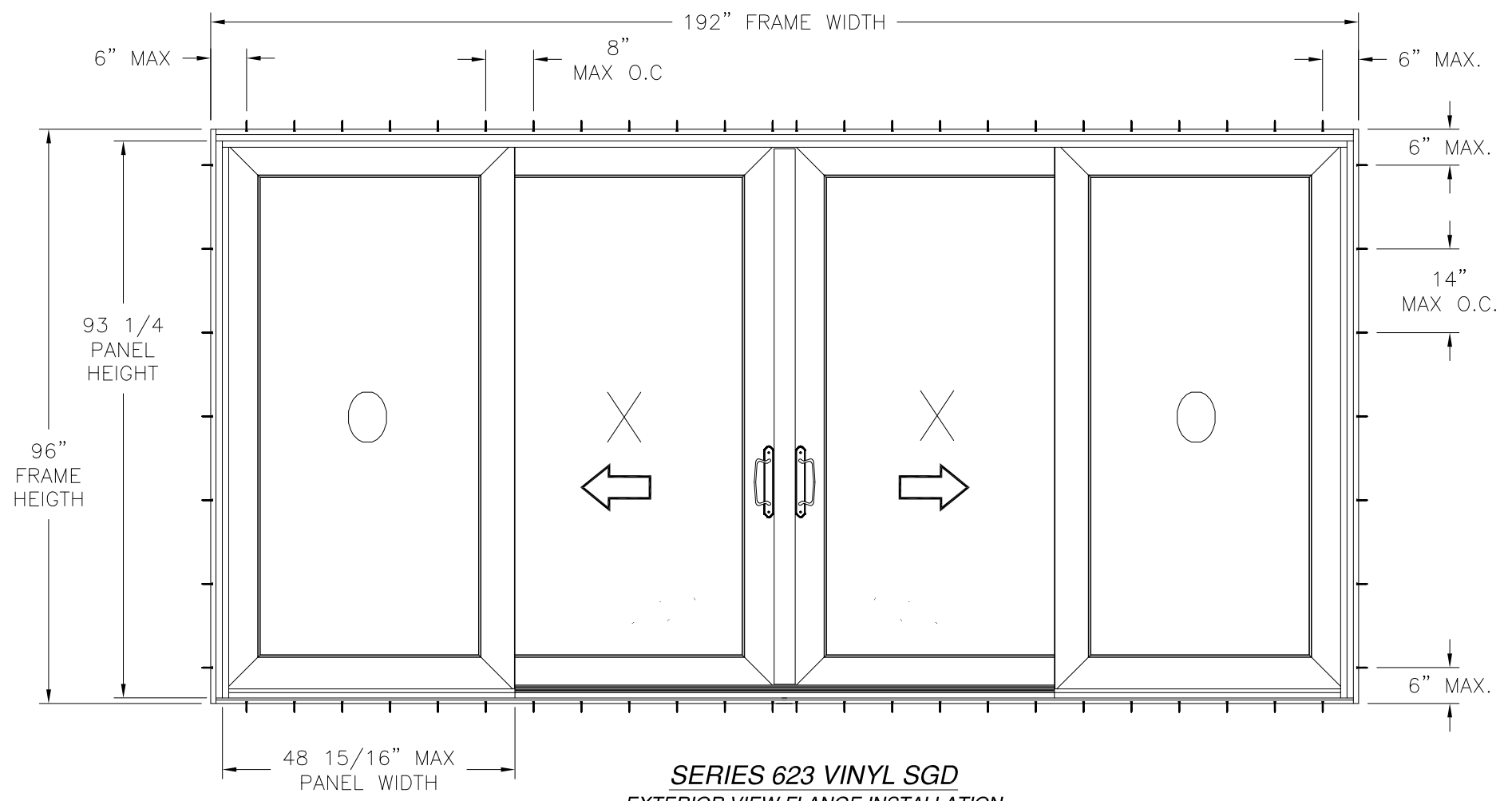
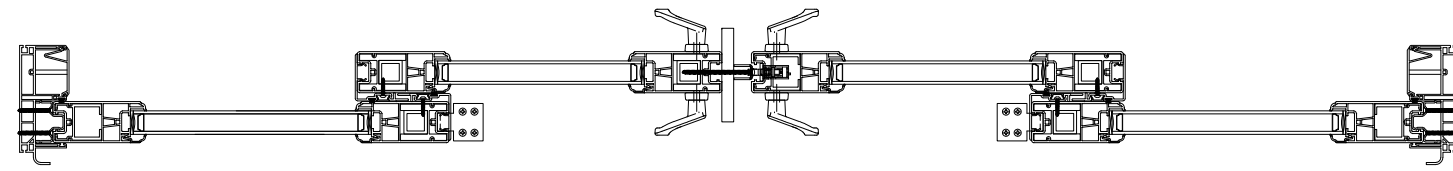

SERIES 623 VINYL SGD
EXTERIOR VIEW FLANGE INSTALLATION

DESIGN PRESSURE RATING	IMPACT RATING
±50.0PSF	NONE

4 PANELS SHOWN, UNLIMITED CONFIGURATIONS UP TO 4 PANELS IS APPLICABLE
AS LONG AS INDIVIDUAL PANEL AREA DOES NOT EXCEED 31.69 FT²

- NOTES:
- PANEL SIZE: 48 15/16" X 93 1/4"
 - D.L.O.: 40 3/4" X 85"

HARDWARE SCHEDULE

A.	(4) STEEL ADJUSTABLE TANDEM ROLLER AT EACH OPERABLE PANEL BOTTOM RAIL CORNER
B.	(2) INSIDE/OUTSIDE PULL HANDLE AT LOCK STILE OF OPERABLE PANEL
C.	(1) AMESBURY 2 POINT LOCK AT STILE OF OPERABLE PANEL, 38 1/4" FROM BOTTOM OF PANEL
D.	(1) STEEL KEEPER AT LATCH STILE OF OPERABLE PANEL, 38 1/4" FROM BOTTOM OF PANEL
E.	(1) H SHAPED ALUMINUM REINFORCEMENT AT EACH FIXED PANEL ASTRAGAL AND INTERLOCK STILES AND OPERABLE PANEL INTERLOCK STILE

STERGIS WINDOWS & DOORS
79 WALTON STREET
ATTLEBORO, MA 02703

SERIES 623.620 VINYL SGD
NON-IMPACT
ELEVATION

DRAWN: A.R.	DWG NO. 08-03378	REV -
SCALE NTS	DATE 02/06/19	SHEET 3 OF 7

L. ROBERTO LOMAS P.E.
1432 WOODFORD RD LEWISVILLE, NC 27023
434-688-0609 rllomas@rlomaspe.com

SIGNED: 02/06/2019

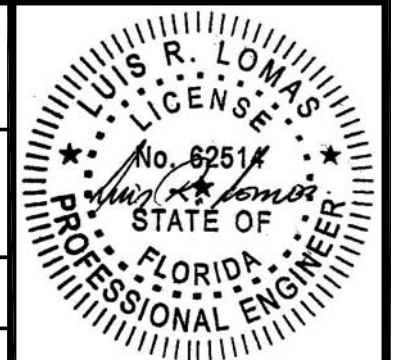

Luis R. Lomas P.E.
FL No.: 62514

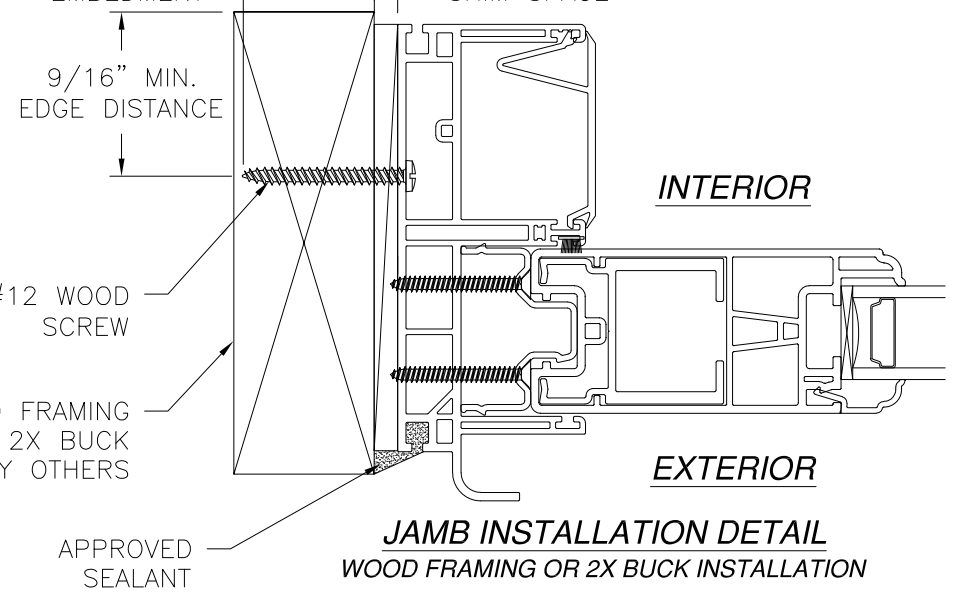
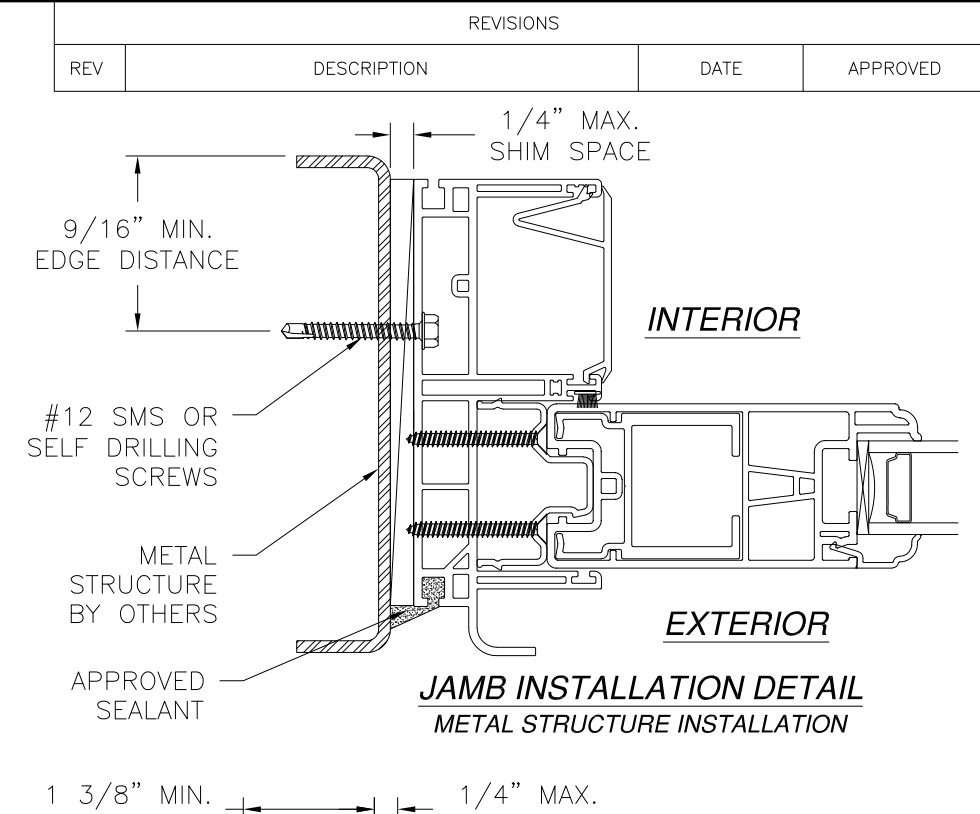
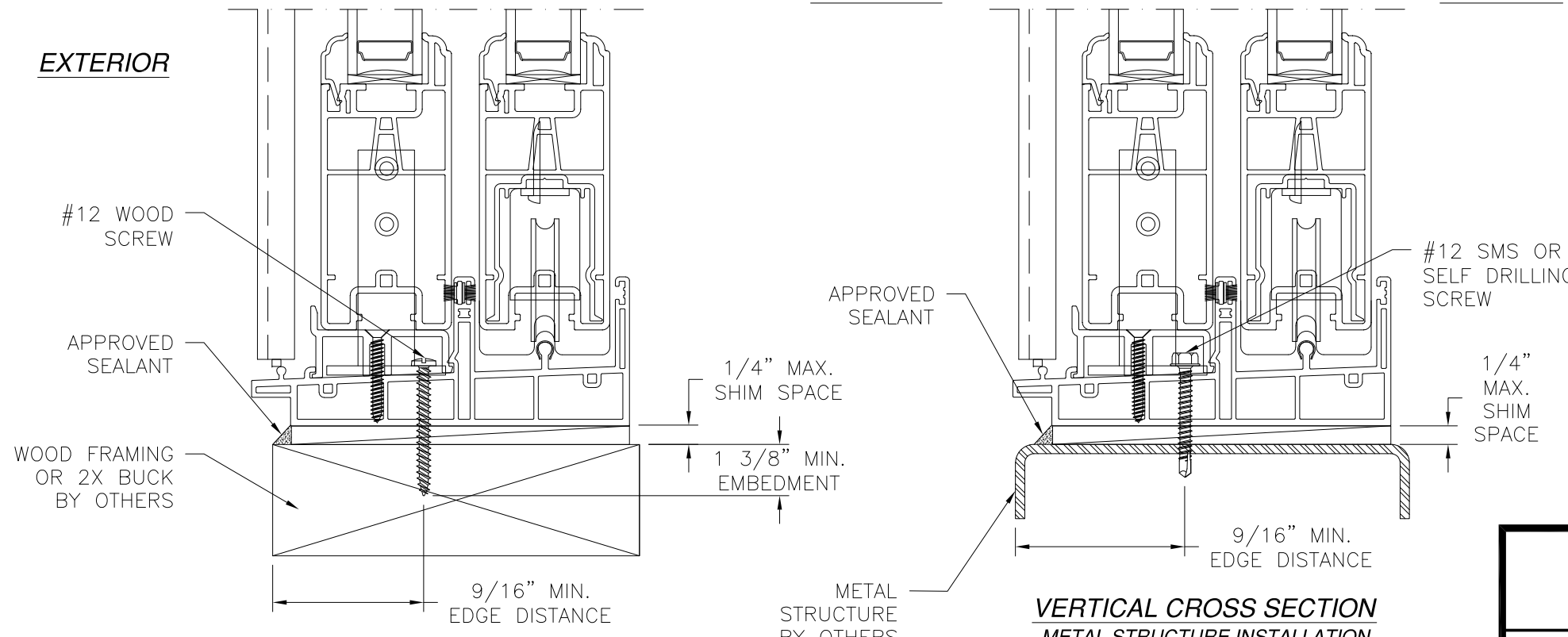
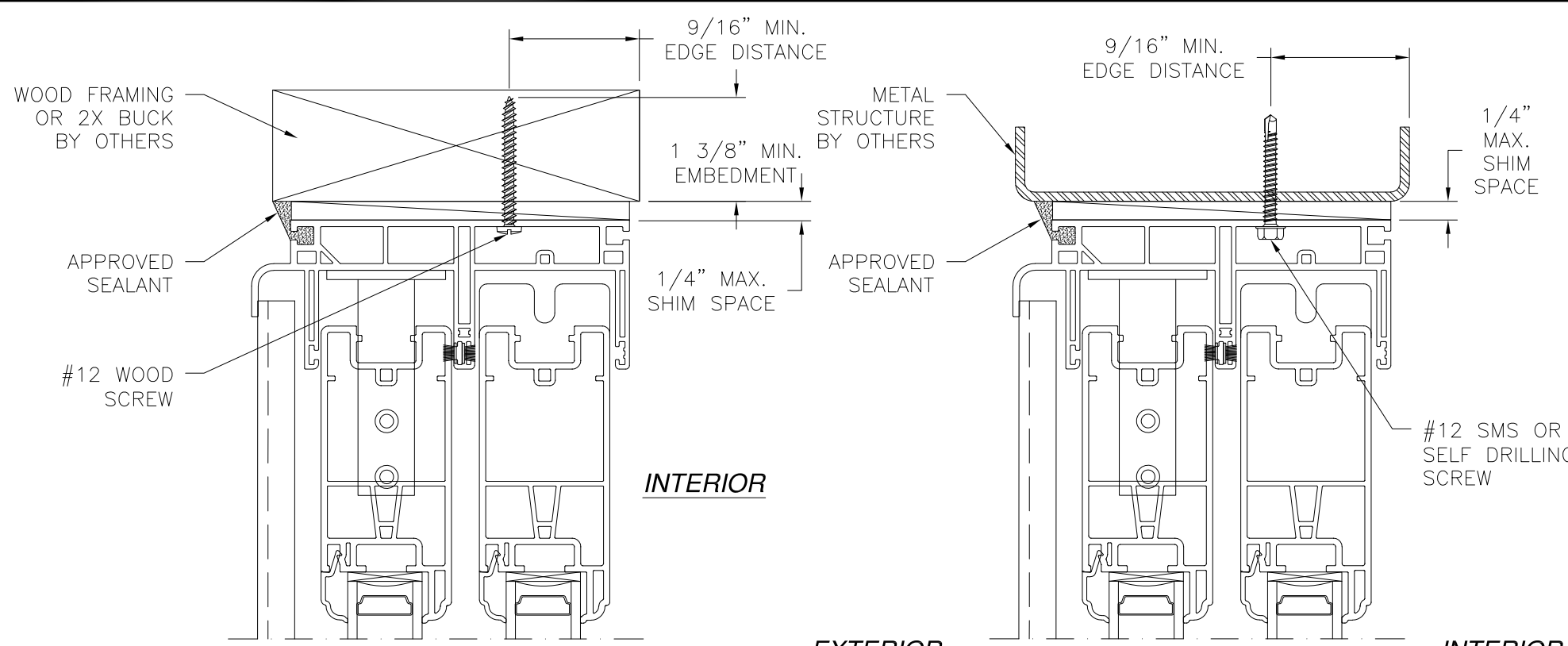

REVISIONS			
REV	DESCRIPTION	DATE	APPROVED

VERTICAL CROSS SECTION
WOOD FRAMING OR 2X BUCK INSTALLATION

VERTICAL CROSS SECTION
METAL STRUCTURE INSTALLATION

JAMB INSTALLATION DETAIL
METAL STRUCTURE INSTALLATION

JAMB INSTALLATION DETAIL
WOOD FRAMING OR 2X BUCK INSTALLATION

- NOTES:**
1. INTERIOR AND EXTERIOR FINISHES, BY OTHERS, NOT SHOWN FOR CLARITY.
 2. PERIMETER AND JOINT SEALANT BY OTHERS TO BE DESIGNED IN ACCORDANCE WITH ASTM E2112

STERGIS WINDOWS & DOORS
79 WALTON STREET
ATTLEBORO, MA 02703

SERIES 623.620 VINYL SGD
NON-IMPACT
INSTALLATION DETAILS

DRAWN: A.R.	DWG NO. 08-03378	REV -
SCALE NTS	DATE 02/06/19	SHEET 4 OF 7

L. ROBERTO LOMAS P.E.
1432 WOODFORD RD LEWISVILLE, NC 27023
434-688-0609 rllomas@rlomaspe.com

SIGNED: 02/06/2019

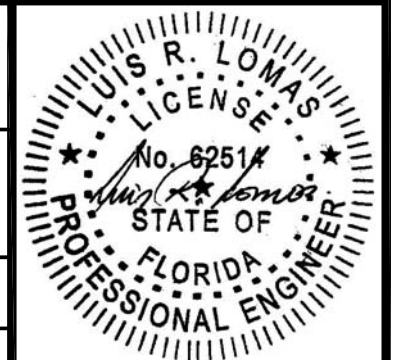

Luis R. Lomas P.E.
FL No.: 62514

REVISIONS			
REV	DESCRIPTION	DATE	APPROVED

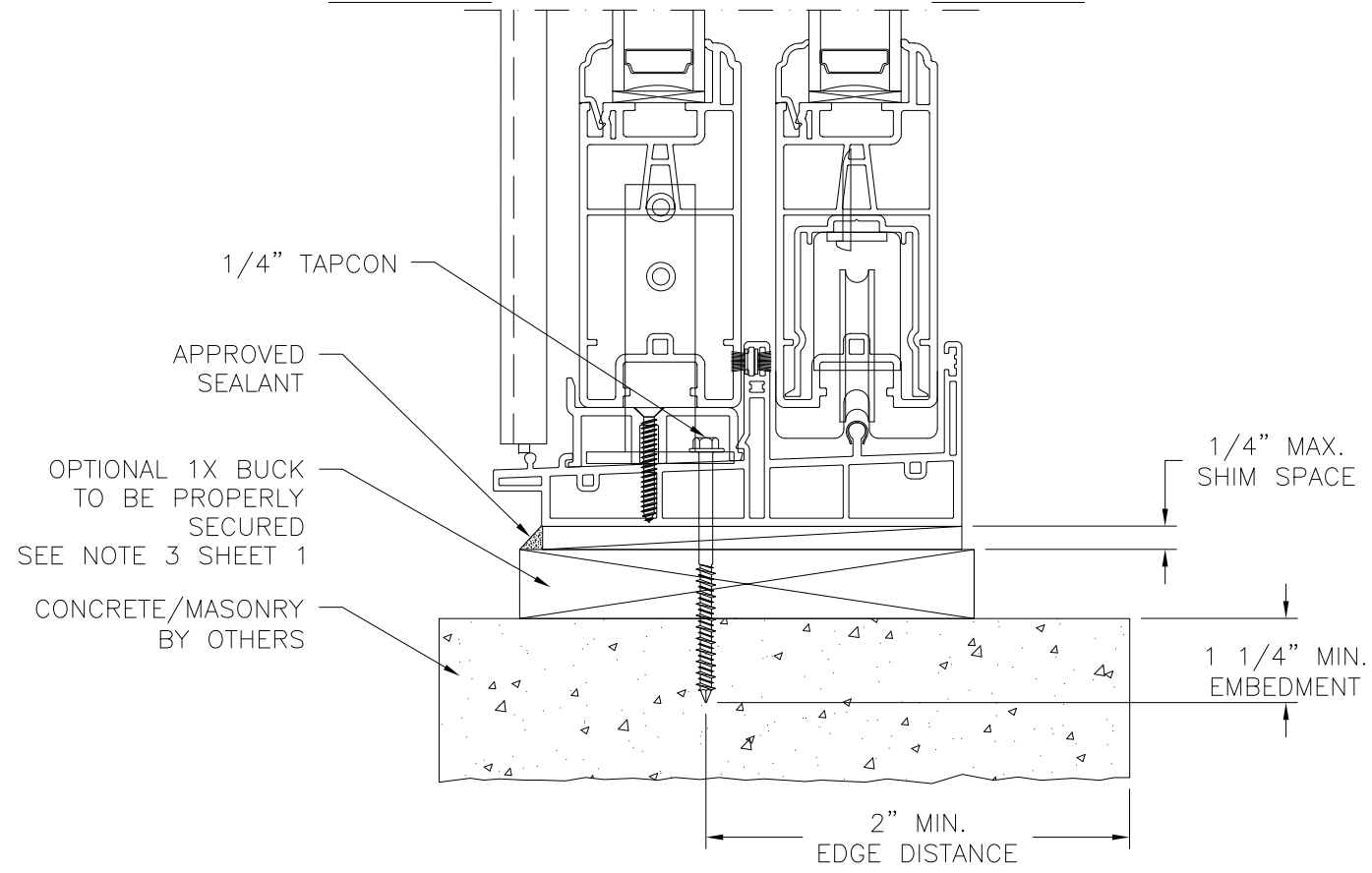
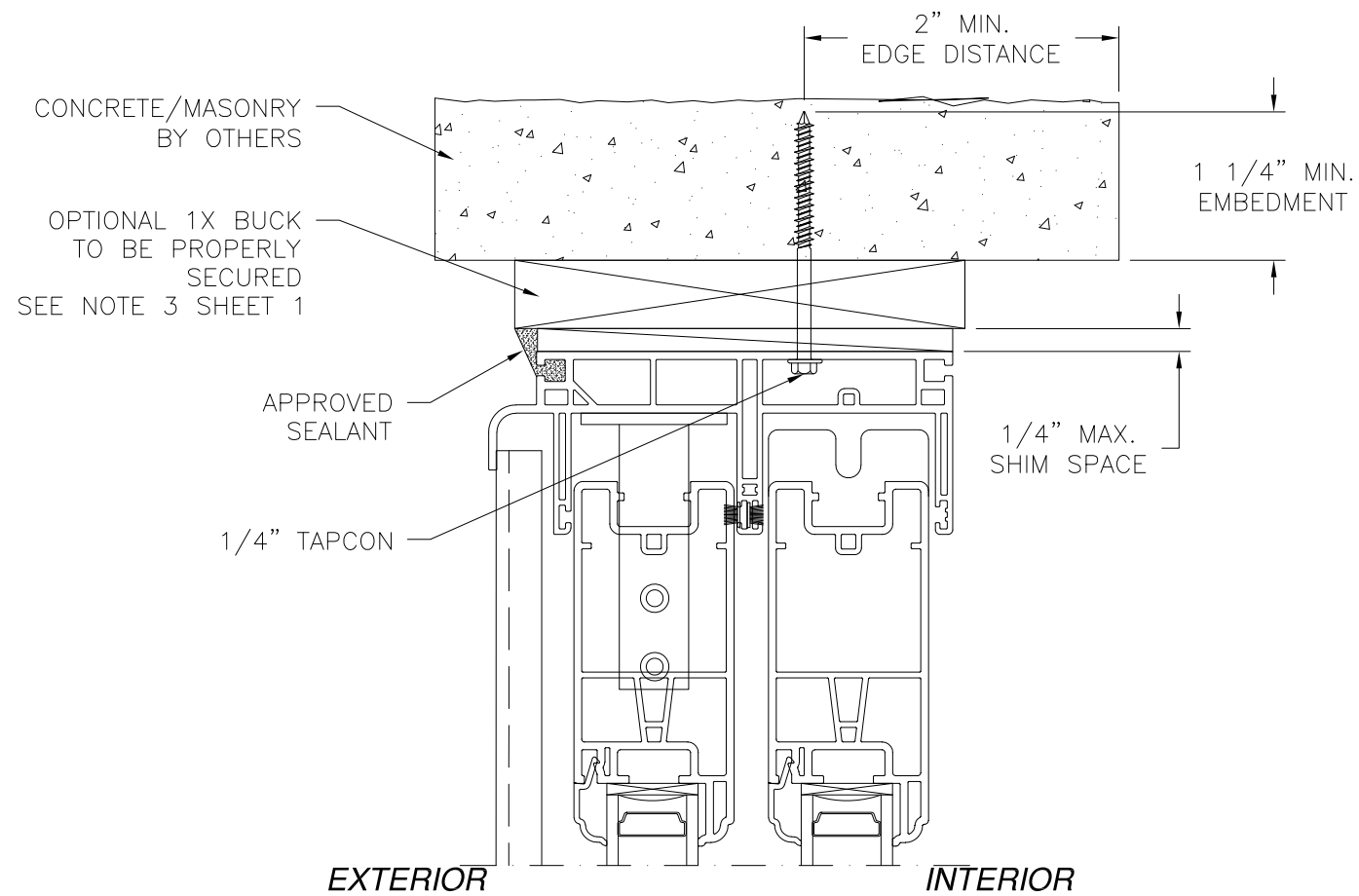

VERTICAL CROSS SECTION
CONCRETE/MASONRY INSTALLATION

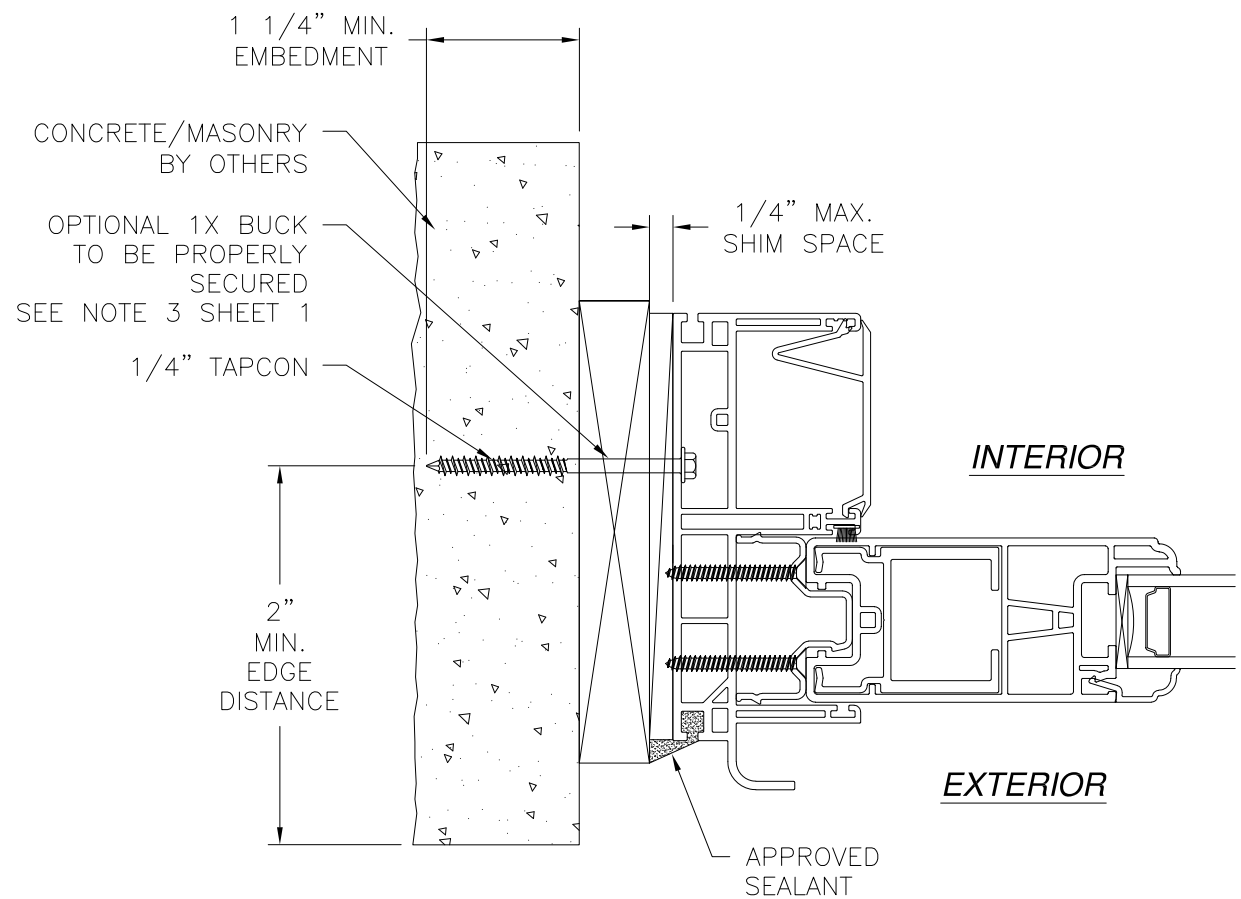

JAMB INSTALLATION DETAIL
CONCRETE/MASONRY INSTALLATION

- NOTES:**
1. INTERIOR AND EXTERIOR FINISHES, BY OTHERS, NOT SHOWN FOR CLARITY.
 2. PERIMETER AND JOINT SEALANT BY OTHERS TO BE DESIGNED IN ACCORDANCE WITH ASTM E2112

SIGNED: 02/06/2019

<p>STERGIS WINDOWS & DOORS 79 WALTON STREET ATTLEBORO, MA 02703</p>		
<p>SERIES 623.620 VINYL SGD NON-IMPACT INSTALLATION DETAILS</p>		
DRAWN: A.R.	DWG NO. 08-03378	REV -
SCALE NTS	DATE 02/06/19	SHEET 5 OF 7
<p>L. ROBERTO LOMAS P.E. 1432 WOODFORD RD LEWISVILLE, NC 27023 434-688-0609 rllomas@rlomaspe.com</p>		

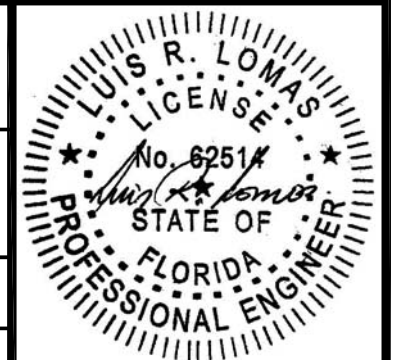

Luis R. Lomas P.E.
FL No.: 62514

REVISIONS			
REV	DESCRIPTION	DATE	APPROVED

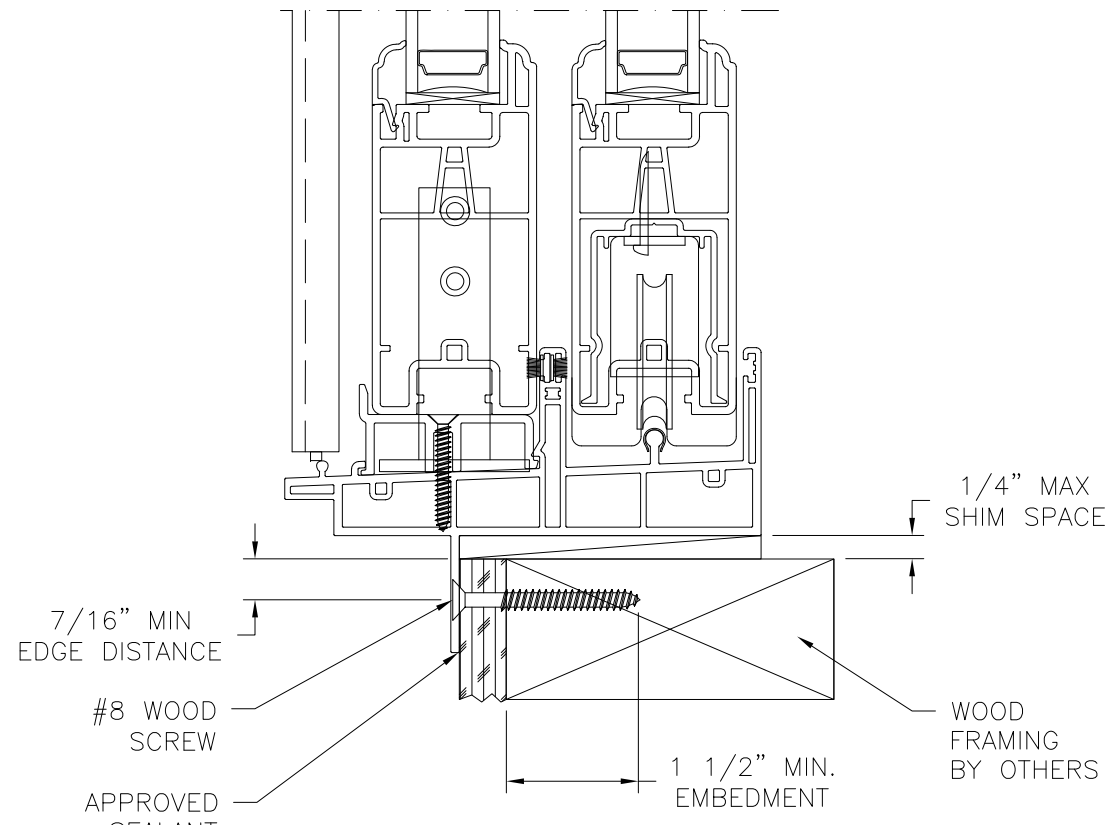
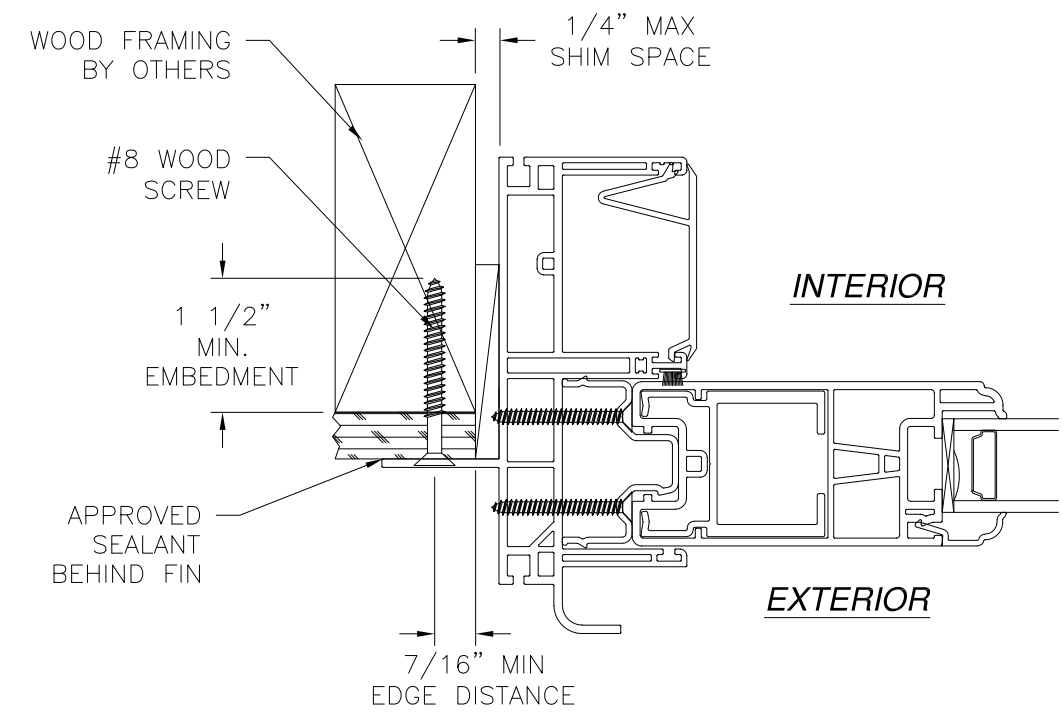
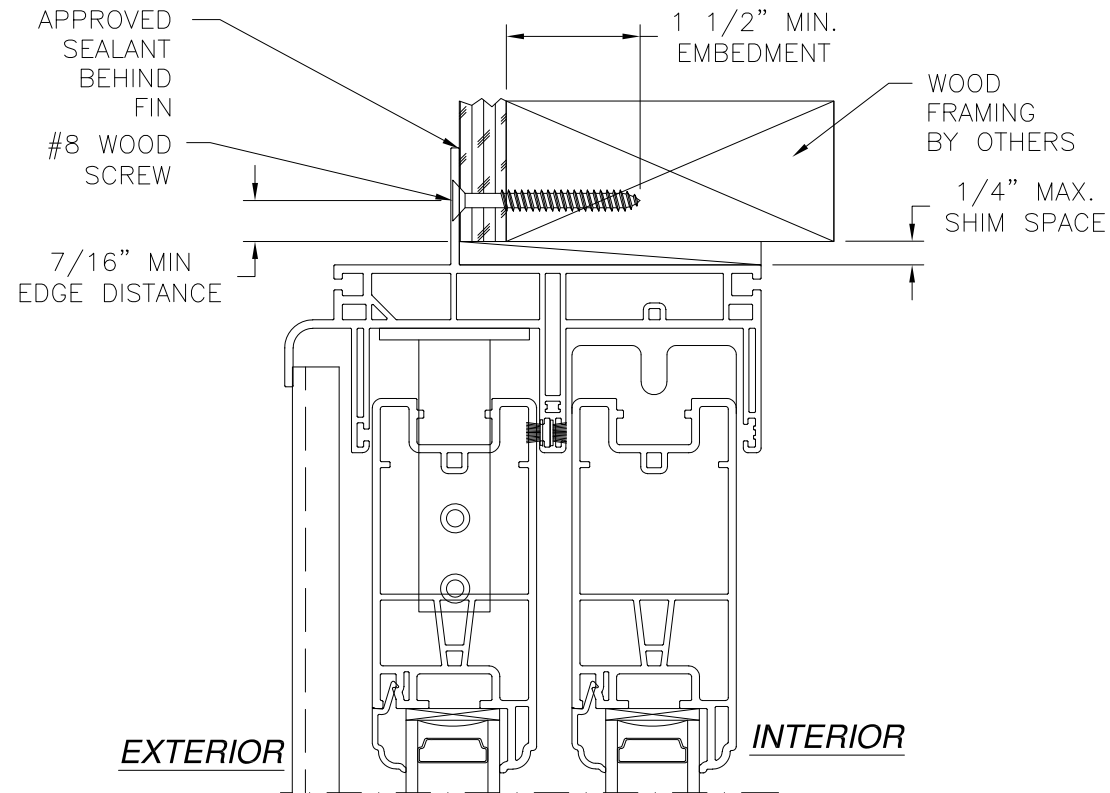

JAMB INSTALLATION DETAIL
WOOD FRAMING OR 2X BUCK INSTALLATION

VERTICAL CROSS SECTION
WOOD FRAMING OR 2X BUCK INSTALLATION

- NOTES:**
1. INTERIOR AND EXTERIOR FINISHES, BY OTHERS, NOT SHOWN FOR CLARITY.
 2. PERIMETER AND JOINT SEALANT BY OTHERS TO BE DESIGNED IN ACCORDANCE WITH ASTM E2112

SIGNED: 02/06/2019

STERGIS WINDOWS & DOORS 79 WALTON STREET ATTLEBORO, MA 02703		
SERIES 623.620 VINYL SGD NON-IMPACT FIN INSTALLATION DETAILS		
DRAWN: A.R.	DWG NO. 08-03378	REV -
SCALE NTS	DATE 02/06/19	SHEET 6 OF 7
L. ROBERTO LOMAS P.E. 1432 WOODFORD RD LEWISVILLE, NC 27023 434-688-0609 rllomas@rlomaspe.com		

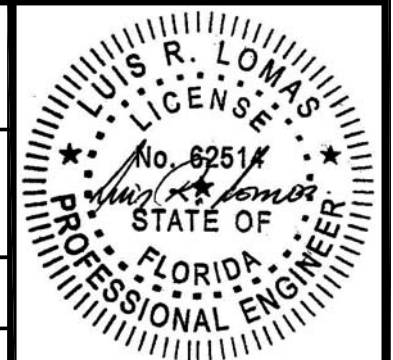

Luis R. Lomas P.E.
FL No.: 62514

REVISIONS			
REV	DESCRIPTION	DATE	APPROVED

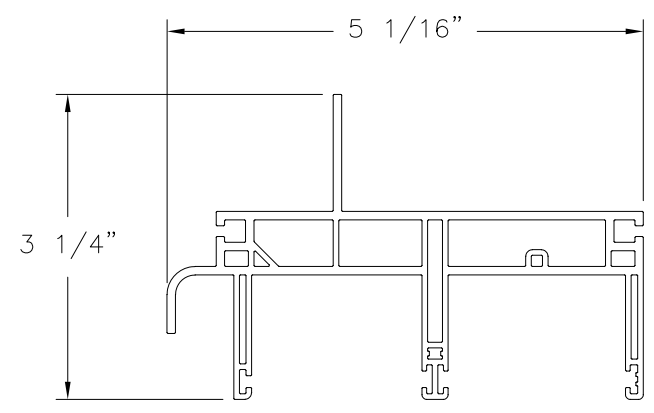

**SILL AND HEAD FRAME
FIN INSTALLATION**
RIGID PVC

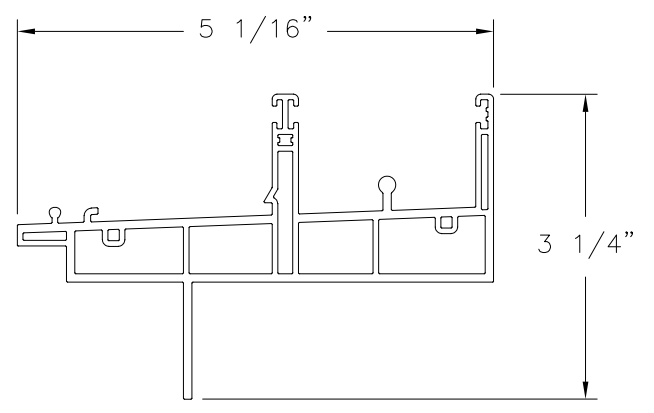

**JAMB FRAME
FIN INSTALLATION**
RIGID PVC

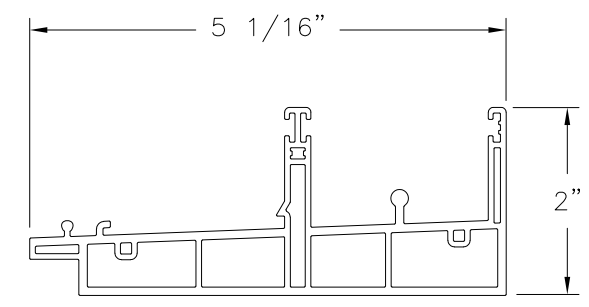

SILL AND HEAD FRAME
RIGID PVC

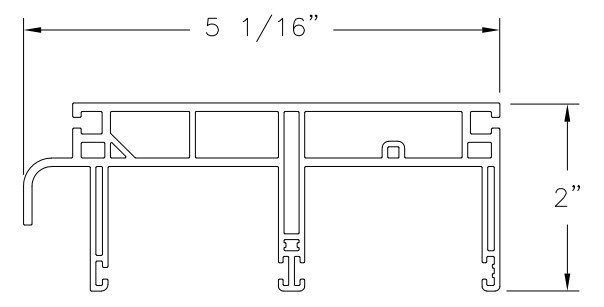

JAMB FRAME
RIGID PVC

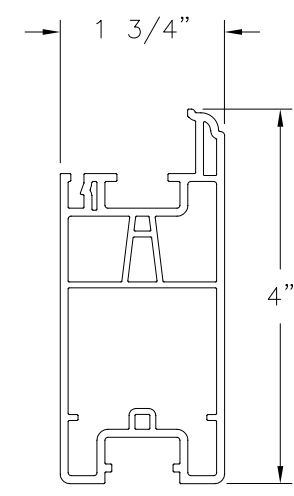

PANEL STILE
RIGID PVC

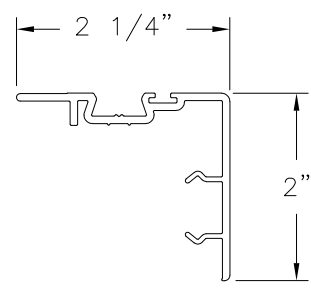

PANEL INTERLOCK
RIGID PVC

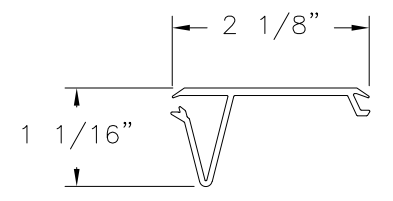

JAMB COVER PLATE
RIGID PVC

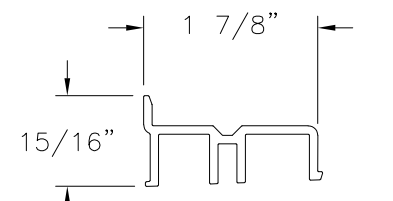

SILL COVER PLATE
RIGID PVC

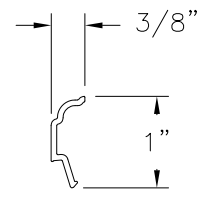

GLAZING BEAD
RIGID PVC

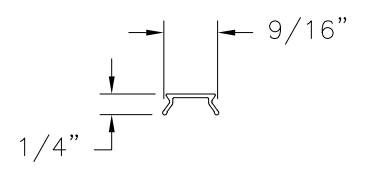

**SLIDER PANEL
RETAINING CLIP**
RIGID PVC

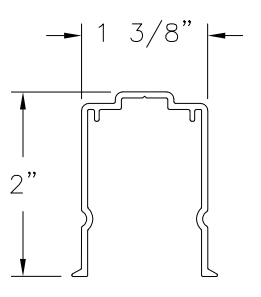

**BOTTOM RAIL
REINFORCEMENT**
ALUMINUM 6063-T5

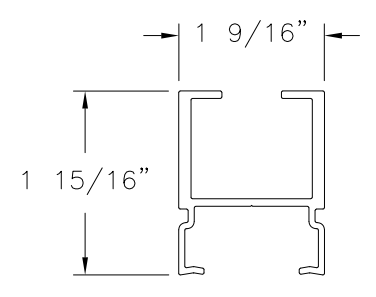

**TOP RAIL/JAMB
REINFORCEMENT**
ALUMINUM 6063-T5

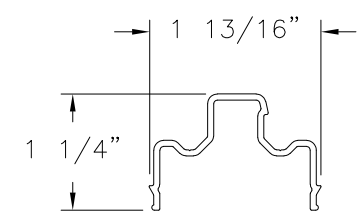

**JAMB
REINFORCEMENT**
ALUMINUM 6063-T5

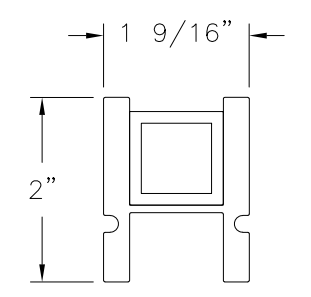

**ACTIVE/FIXED PANEL
H-REINFORCEMENT**
ALUMINUM 6063-T5

STERGIS WINDOWS & DOORS
79 WALTON STREET
ATTLEBORO, MA 02703

SERIES 623.620 VINYL SGD
NON-IMPACT
COMPONENTS

DRAWN: A.R.	DWG NO. 08-03378	REV -
SCALE NTS	DATE 02/06/19	SHEET 7 OF 7

L. ROBERTO LOMAS P.E.
1432 WOODFORD RD LEWISVILLE, NC 27023
434-688-0609 rllomas@rlomaspe.com

SIGNED: 02/06/2019



Luis R. Lomas P.E.
FL No.: 62514